



14500 Coy Drive, Grass Lake, Michigan 49240
734-475-2200 E-mail: sales@coylab.com
www.coylab.com

O₂ Controller Instruction Manual

Index

	Page
Warranty	2
Warnings	3
General Description	4
Setup Procedure (O ₂ Controller)	5
Setup Procedure (Gas Supply)	7-13
System Function	16
Operation and Calibration	17

WARRANTY

This product is warranted against defects in material and workmanship during the first 12 months after original date of shipment.

The factory will, at its option, repair or replace defective material within this period at no charge for parts and labor.

All returns or exchanges must first be authorized by COY LABORATORY PRODUCTS, INC.

PHONE: 734-475-2200

FAX: 734-475-1846

COY LABORATORY PRODUCTS, INC.

14500 COY DRIVE

GRASS LAKE, MI 49240

The responsibility of COY LABORATORY PRODUCTS, INC. is limited to the purchase price of this product, and COY LABORATORY PRODUCTS, INC. will not be responsible for any consequential damages.

This warranty does not cover damage in shipment or damage as a result of improper use or maintenance of this product. This warranty does not cover damages caused by excessive line transients on the AC supply line.

WARNINGS

- 1. The calibration of the sensor must be checked frequently as erroneous low readings can result from a degraded sensor.**
- 2. Gas pressures into the back of the Oxygen Controller must not exceed 10 PSI.**
- 3. The output of the O₂ Controller must be regulated using the flow controls on the front of the O₂ Controller. Do not to exceed specified gas flow (SCFH) as stated in figure # 12. If gas flow exceeds the applications stated gas flow then O₂ levels can change quicker then O₂ sensor and O₂ controller can react. This can create an unstable environment.**
- 4. Never obstruct gas flow in or out of the Chamber Relief Valves.**
- 5. Never attempt to service the O₂ Controller. Call COY LABORATORY PRODUCTS, INC. for assistance.**
- 6. Never put an open flame or create a spark in a Chamber, especially under hyperoxic conditions.**
- 7. The O₂ sensor cell membrane is delicate. Do not scratch, puncture, or permit sharp objects to touch the cell face. Sensor failure due to mishandling voids the sensor warranty.**
- 8. If the O₂ sensor becomes wet you will need to take it out of the chamber and let it dry out in room atmosphere for at least 24 hours before use.**
- 9. Do Not Hold O₂ sensor straight up. It needs to be in the horizontal position or facing straight down.**
- 10. The O₂ sensor will need to be recalibrated every month or so after 6 month to a year of its life.**

General Description

The Oxygen Controller utilizes a unique galvanic sensor to measure up to 100% concentration in atmospheric environment. The sensor is supplied with a 5 foot cord, is temperature compensated, and is totally sealed from the environment. The sensor must not be exposed to pressures exceeding 25 psi (pounds per square inch). There is no membrane replacement or maintenance of the sensor during its expected life of 2 or more years.

All control functions are programmable from the front panel. Self diagnosis with indication of faults is standard. The non-volatile memory retains all process parameters when power is off.

The sensor is always operating and does not require a warm up period. To prolong its life, DO NOT STORE IN A WARM OR HOT AREA. Even when disconnected and in storage, the sensor is working. Storage in a refrigerator will slow the kinetic energy of the cell and prolong its life.

The Oxygen Controller uses a Background Gas to reduce O₂ levels. Throughout this manual the term "BACKGROUND GAS" is used in-place of the main gas (i.e. Nitrogen) being used to reduce the O₂ levels.

O₂ Controller Setup Procedure

1. Remove Controller from the package.
2. Remove the sensor from the bag.
3. Locate the O₂ sensor port on the Chamber/Glove Box/Cabinets.
(*certain custom built units may have different locations for the port based on configurations*)
 - On COY Aluminum Glove Boxes port is located on the center of the back panel.
 - On Coy Polymer Glove Boxes the port is located on the top right side of the glove box.
 - On COY Flexible Vinyl Chamber port is located behind the airlock.
 - On Coy In-Vivo / In-Vitro Cabinets port is located on the top of the cabinet.

Mounting O₂ sensor through Feed Thru-Port

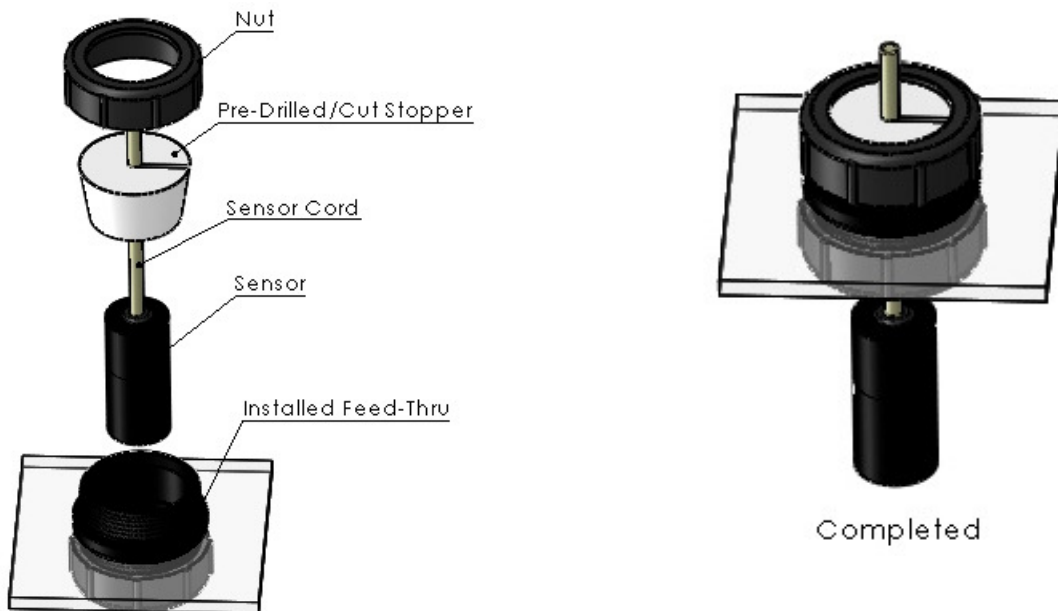

3. Mounting O₂ sensor into chamber:

- Step 1)** Position the Chamber as desired, and then place the Oxygen Controller on the Exterior Shelf Provided (Shelf located on Top of Polymer unit or Side of an Aluminum unit).
- Step 2)** Plug the Oxygen Sensor into the jack on the back of the Controller.
- Step 3)** Feed entire sensor down through the mounting Feed thru port as seen above.
- Step 4)** Using the predrilled, precut rubber stopper insert the O₂ sensor cord. Push the rubber stopper down into the port as far as possible and screw the nut down tightly.

Note: Make sure the sensor hangs about 3-4 inches into the chamber.
Rotate sensor so that serial number is visible.

Figure #2 Rear Panel of Oxygen Controller

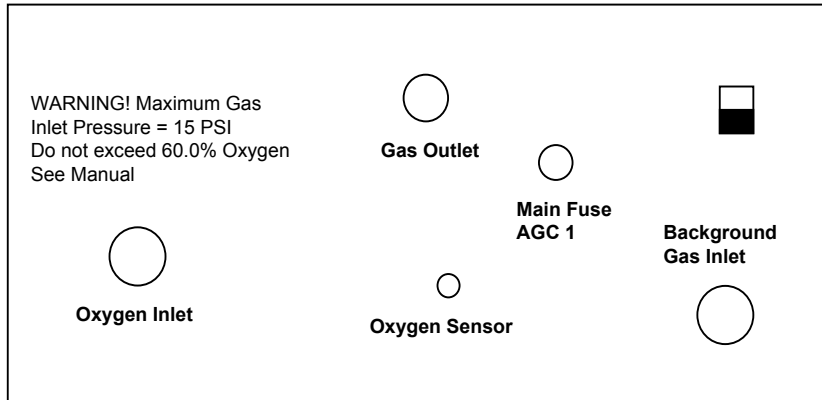

- Determine the correct plumbing diagram below (figures 4 thru 10) for proper plumbing of Chamber/Glove Box/Cabinets. Choose the diagram based on type (chamber/glove box or cabinet) and options (i.e. heated and/or CO₂ controller). Be sure to read any and all notes.
 - Measure and cut a piece of tubing to reach between desired connections. Place a female fitting on each end of tubing. Using figure # 3 place 2 ty-wraps around the hose barb on the female fittings and pull them as tight as possible. Cut off excess ty-wrap.

WHEN CUTTING TUBING, THE ENDS SHOULD BE AS SQUARE AS POSSIBLE

Figure # 3 Tubing connection to Quick Disconnect Fitting

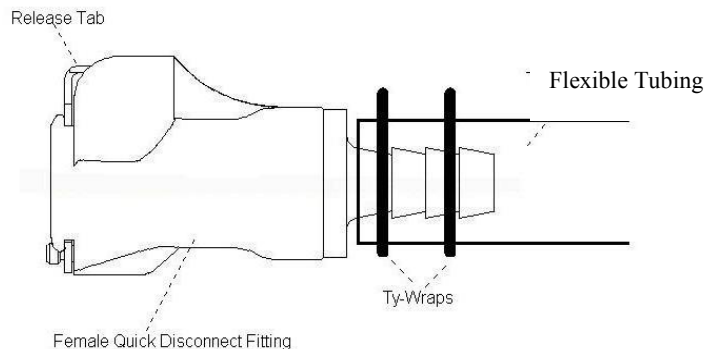

- When fittings are seated correctly to mating ends, you will hear a “click”. When Hyperoxic (above ambient O₂) environment is required; switch connections between the N₂ regulator and O₂ regulator.

Figure # 4 - Hypoxic Chamber/Glove Box, Plumbing Diagram

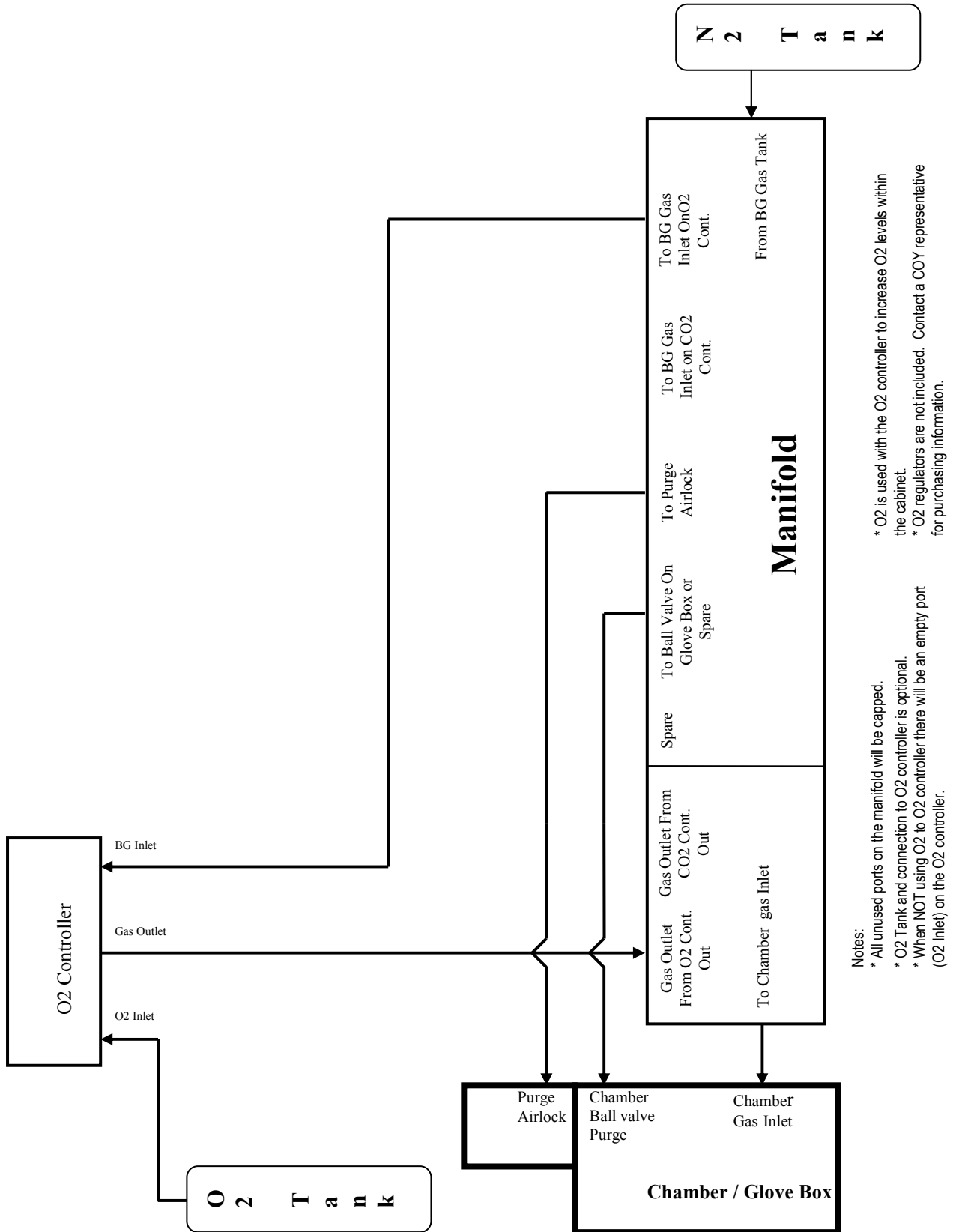
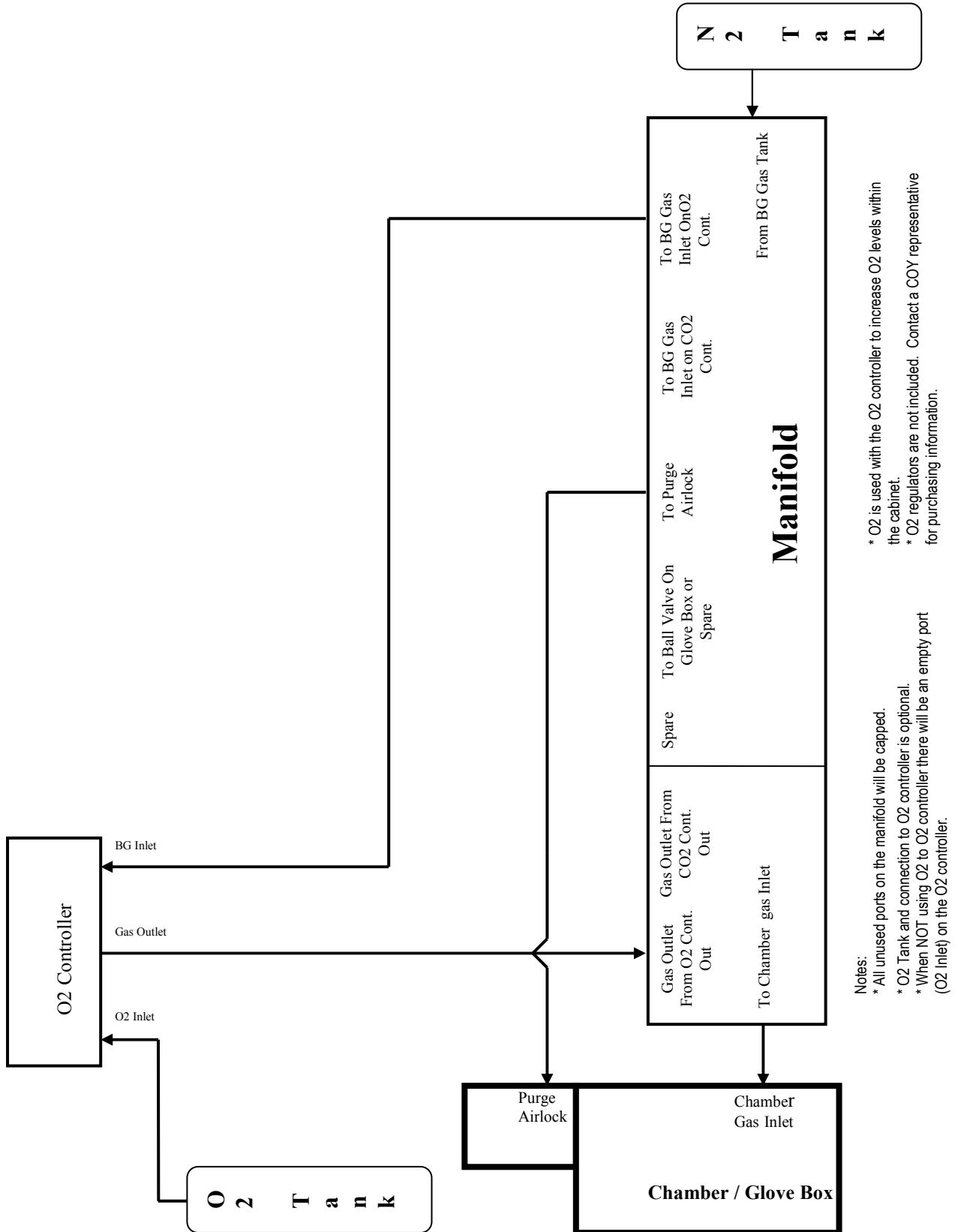
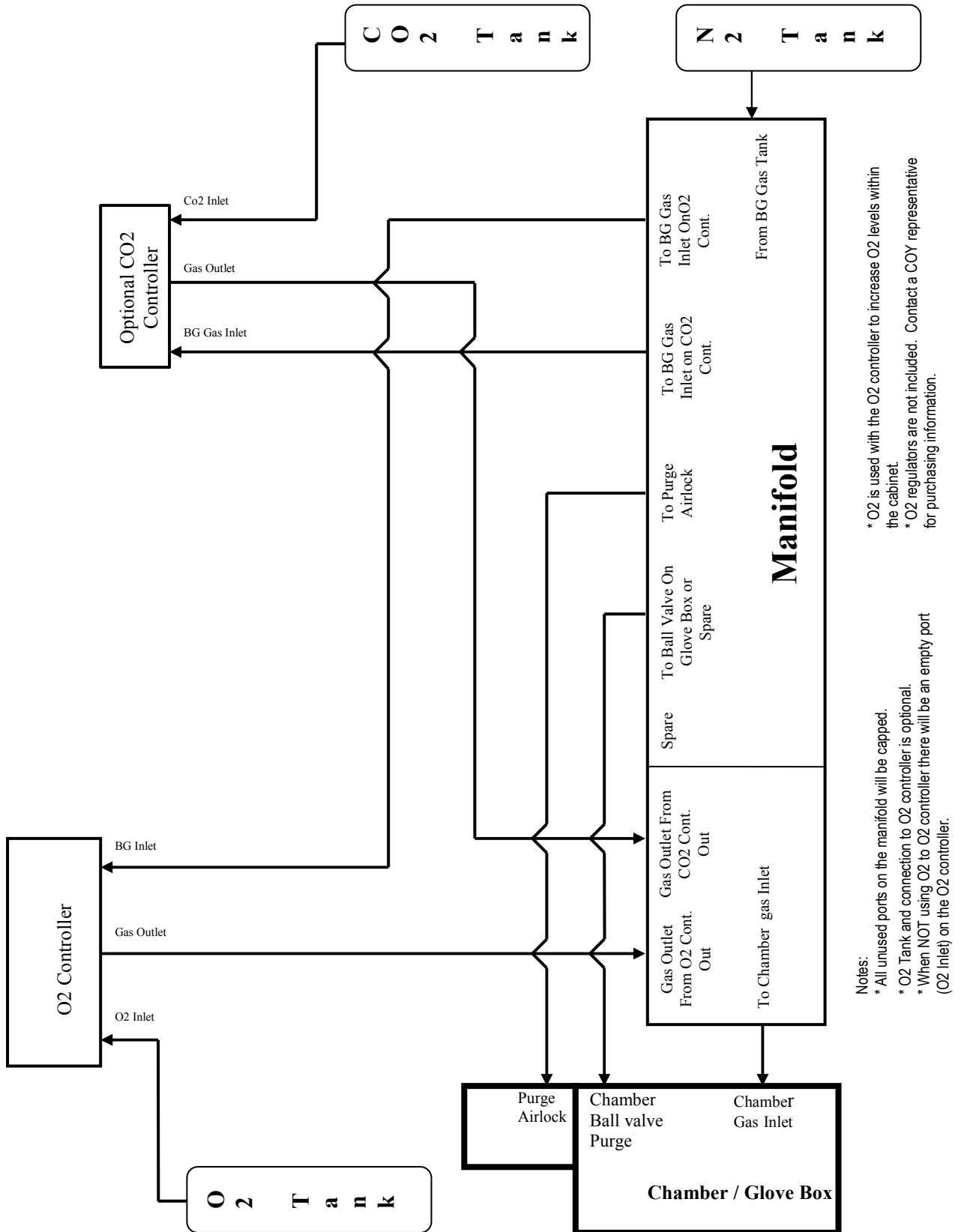

Figure # 5 - Hypoxic Chamber/Glove Box with Heater, Plumbing Diagram



Notes:
 * All unused ports on the manifold will be capped.
 * O₂ Tank and connection to O₂ controller is optional.
 * When NOT using O₂ to O₂ controller there will be an empty port (O₂ Inlet) on the O₂ controller.
 * O₂ is used with the O₂ controller to increase O₂ levels within the cabinet.
 * O₂ regulators are not included. Contact a COY representative for purchasing information.

Figure # 6 - Hypoxic Glove Box with CO₂ Controller, Plumbing Diagram



Notes:
 * All unused ports on the manifold will be capped.
 * O₂ Tank and connection to O₂ controller is optional.
 * When NOT using O₂ to O₂ controller there will be an empty port (O₂ inlet) on the O₂ controller.

* O₂ is used with the O₂ controller to increase O₂ levels within the cabinet.
 * O₂ regulators are not included. Contact a COY representative for purchasing information.

Figure # 7 - Hypoxic Glove Box with Heater and CO₂ Controller, Plumbing Diagram

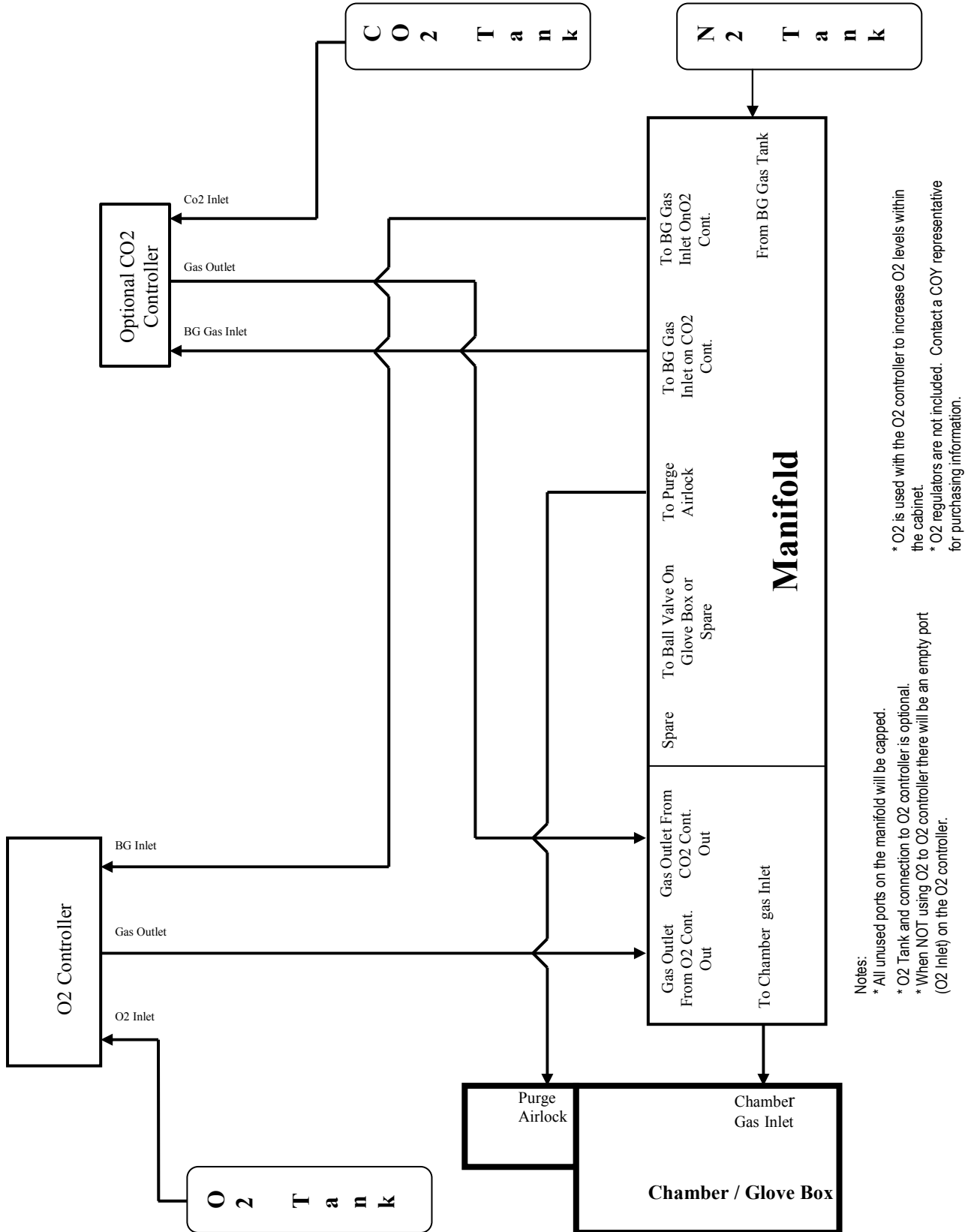
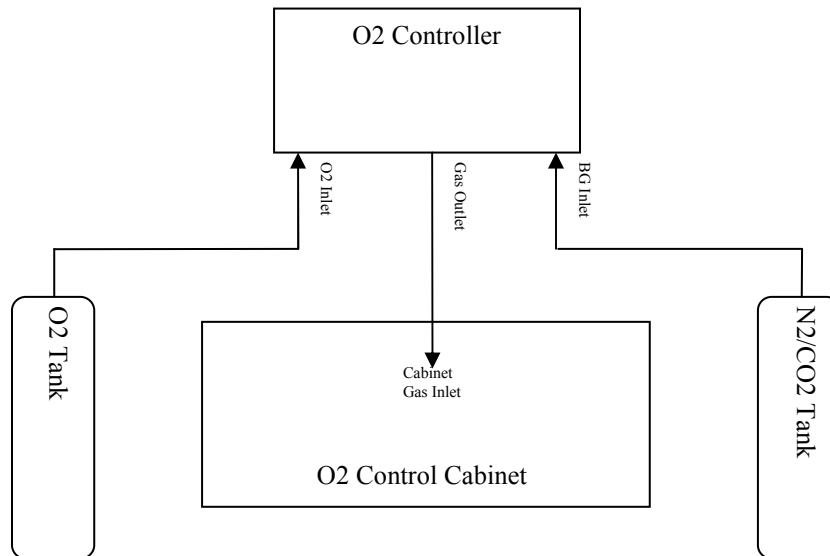

Figure # 8

Set up for In-Vitro O₂ Control Cabinet for Hypoxia or Hyperoxia



Notes:

CO₂ Environment

* To create an environment with CO₂, a background gas mix with CO₂ is required. Refer to the chart in the **Gas Supply Setup** section for more information.

O₂ Controller

* O₂ Tank and connection to O₂ controller is optional.

* When NOT using O₂ to O₂ controller there will be an empty port (O₂ Inlet) on the O₂ controller.

* O₂ is used with the O₂ controller to increase O₂ within the cabinet.

* O₂ regulators are not included. Contact a COY representative for purchasing information.

Figure # 9

Set up for In-Vitro Hypoxic (Cabinet) Cell Culture with Optional CO₂ Controller

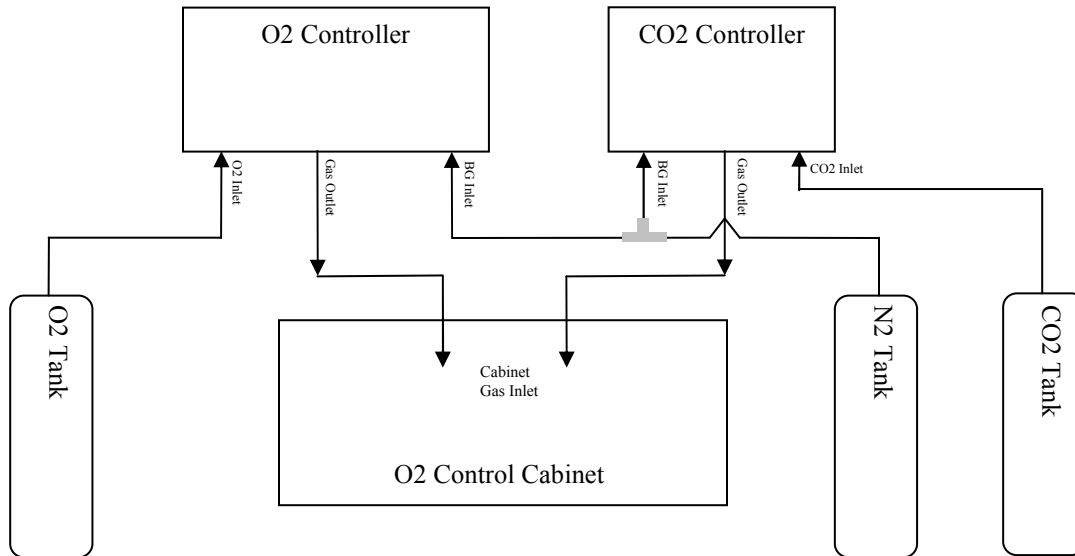

Notes:

CO₂ Controller

- * Background Gas connected to CO₂ controller is optional.
- * When NOT using BG gas to CO₂ controller there will be an empty port (BG Inlet) on the CO₂ controller.
- * Background Gas is used with the CO₂ controller to reduce CO₂ within the cabinet.

O₂ Controller

- * O₂ Tank and connection to O₂ controller is optional.
- * When NOT using O₂ to O₂ controller there will be an empty port (O₂ Inlet) on the O₂ controller.
- * O₂ is used with the O₂ controller to increase O₂ within the cabinet.
- * O₂ regulators are not included. Contact a COY representative for purchasing information.

Figure # 10

Set up for In-Vivo O₂ Control Cabinet for hypoxic or hyperoxic

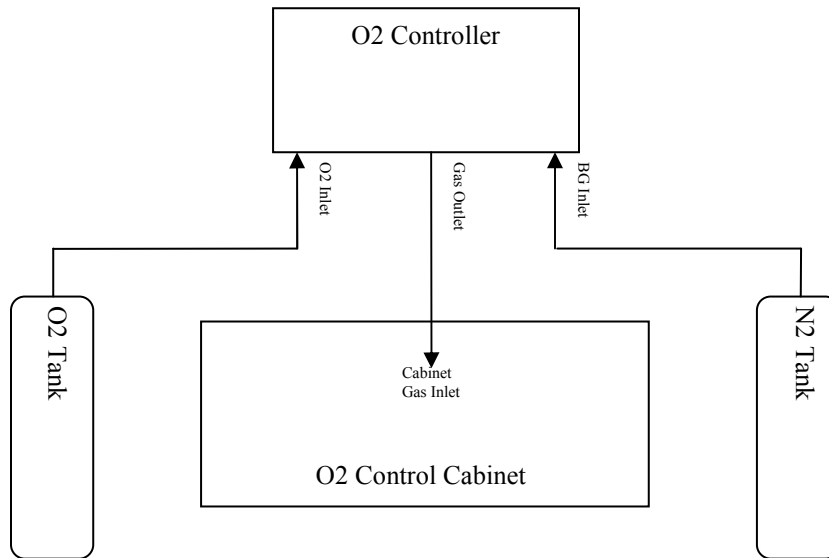

Notes:

* No special notes included.

Gas Supply Setup

Passive CO₂ Control

If optional CO₂ Control System has been purchased skip this section of the manual.

To maintain the 5% CO₂ level required for certain buffers to function properly, use the following table (figure 11) to spike each one of the gases going into the Oxygen Controller with the appropriate level of CO₂ based on desired O₂ levels.

Figure # 11

Desired Concentration of Oxygen	Air Displace to %	%CO ₂ Mix required	Desired % CO ₂	%CO ₂ Concentration in N ₂
20.80	100.00	0.00	5.00	N/A
15.00	72.12	27.88	5.00	17.9310
10.00	48.08	51.92	5.00	9.6296
5.00	24.04	75.96	5.00	6.5823
2.00	9.62	90.38	5.00	5.5319
1.00	4.81	95.19	5.00	5.2525
0.50	2.40	97.60	5.00	5.1232
0.10	0.48	99.52	5.00	5.0242

System Function

The Oxygen Controller is intended to maintain an oxygen level in a Chamber/Glove Box/Cabinet by sensing the current concentration, and then opening the appropriate solenoid valve to allow gas to flow and purge the system. The Oxygen set point is used to set the oxygen range desired in the chamber. The Controller has been programmed to maintain an oxygen set point of +/- 0.2 %, this is the **Control Tolerance**.

Under normal use, only one gas line will be open at a time. The gas flow must be adjusted using the Flow Meters on the front of the Controller. *The gas flow on the Flow Meters can only be adjusted while gas is flowing through that particular Valve.* To adjust the Flow Meters, simply turn the black Knob on the front of the Flow Meter. Clockwise restrict flow, counter clockwise increases flow. *Reference figure # 12 for O₂ Controller gas flow settings.*

UNDER NO CIRCUMSTANCE SHOULD THE INLET PRESSURE EXCEED 10 PSI. GAS PRESSURES IN EXCESS OF 10 PSI MAY DAMAGE THE O₂ CONTROLLER AND VOID THE WARRANTY.

To obtain uniform O₂ concentration throughout the Chamber/Glove Box/Cabinet, the small circulating fan must be on at ALL times. Please note that in Chamber/Glove Box the addition of a COY Fan Box (heated or unheated) may eliminate the need for this fan, depending upon the size of the chamber.

The alarm (AL) and temperature (C°/F°) functions are not included with O₂ Controller; therefore, these indicator lights will not work.

During operation, the Chamber/Glove Box will pressurize so that the sleeves may begin to stand out. This excess pressure will be removed by the COY Automatic pressure relief valves installed on the COY Chamber/Glove Boxes. Be sure that these pressure relief valves are not blocked.

Below are recommended Flow Rates

FIGURE # 12

Type/Size	Flow Rate (SCFH)	Flow Rate (SCFH)
<i>Polymer and Aluminum, Chamber / Glove Box</i>	O ₂ Gas*	Background Gas
Mini Polymer	≤ 2	≤ 10
1 Person Polymer/Aluminum	≤ 2	≤ 10
2 Person Polymer	≤ 4	≤ 20
2 Person Aluminum	≤ 6	≤ 30
<i>Flexible Vinyl Units</i>		
One Person	≤ 8	≤ 50
Two Person	≤ 10	≤ 60
Mini	≤ 4	≤ 40
<i>In-Vitro Cabinets</i>		
Model 1	< 0.2	≤ 1
Model 2	< 0.2	≤ 1.5
Model 3	≤ 0.2	≤ 2.5
Model 4	≤ 0.4	≤ 4
<i>In-Vivo Cabinets</i>		
Model 15	≤ 1	≤ 6
Model 30	≤ 2	≤ 10
Model 60	≤ 4	≤ 20

*NOTE: The O₂ Flow Rates assume a 100% tank of O₂ is used. For forced air or other % of O₂ rates will have to be increased.

Operation/set point of O₂ Controller

1. Plug the Controller into an electrical outlet.
2. Turn the unit on using the rocker switch on the back.
3. After going through a self test routine, the display will show a red and green number. The red number indicates Present Value (PV) and the measured O₂ concentration and the green number is the Oxygen Set Point Value (SV).
4. Use Figure # 13 to adjust the set point. Press the ▲▼ keys to adjust the SV (green numbers displayed) to desired O₂ setting.

Figure # 13 - O₂ Controller Display



Top Red Number – PV (present value)

Bottom Green Number – SV (set-point value)

Red Number on Side – Indicate gas output ON
1 = O₂ Gas / 2 = Background Gas

▲ ▼ Keys – Adjust SV up or down

⌂ Key – Not Used

∞ Key – Not Used

EZ Key – Not Used

Yellow Zone Indicator – Not Used

5. Once SV display is adjusted to desired O₂ setting the controller is ready to start controlling O₂ in the Chamber/Glove Box/Cabinet.

Calibration of the O₂ Controller

If the High accuracy kit was purchased please follow Calibration instructions for High Accuracy manual. If you cannot find the High Accuracy calibrations manual please contact Coy. techservice@coylab.com

Do Not Place O₂ sensor straight up. It needs to be in the horizontal position or facing straight down.

The sensor has an expected life of greater than 2 years. During that time, there may be a downward drift in the O₂ measurements. It is best to periodically check the calibration.

To do this:

1. Remove the sensor from the Chamber.
2. Plug the opening with the sensor fitting to maintain chamber integrity.
3. **Allow the sensor to equilibrate to ambient conditions for at least 30 minutes.**
4. The ambient oxygen concentration should read 20.9% +/- 1%.
5. If it does not, adjust the percent potentiometer (labeled %) on the front of the O₂ Controller until 20.9% +/-1% is read.

To test for zero:

1. Place the sensor in a 100% nitrogen atmosphere.
2. Allow it to equilibrate for 30 minutes.
3. The Controller display should read 0%.
4. If it does not, adjust the zero potentiometer (labeled Zero) on the front panel to 0%.

Contact Coy Laboratory Products, Inc. if the sensor requires frequent recalibration at 734-475-2200 or email techservice@coylab.com.